

Elliptically polarized x-rays from a standard undulator

S. D. Shastri

School of Applied and Engineering Physics, Cornell University

Under suitable conditions, some samples, such as magnetic materials, scatter or absorb x-rays in a manner that can be quite rich in polarization dependence. Magnetic, nuclear resonance, and even electronic (nonmagnetic) resonance scattering can exhibit polarization-mixing phenomena where an incident linear polarization in (or out of) the diffraction plane is not conserved in the scattering process¹. Circular dichroism is the occurrence of different absorption coefficients for left and right circularly polarized radiation² (see article by J. C. Lang on page 26).

All this has resulted in an interest in the generation of elliptically polarized x-rays, particularly circularly polarized x-rays where the handedness (i.e. helicity) can be "flipped". In addition to the use of off-orbital-plane bend magnet radiation, researchers have pursued this end on two fronts: the building of special (helical or asymmetric) insertion devices³ and the development of x-ray "phase-plates" based on perfect crystal optics⁴.

A scheme of the latter approach

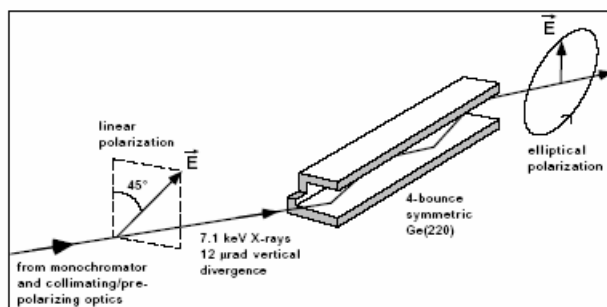

(Figure 1) The phase-shifting Ge(220) channel-cut crystal.

was tested by us⁵ under the high-brightness conditions of a standard undulator. In this method⁶ polarization selection is achieved by precise control of the incident angle of a collimated, 45-degree linearly polarized beam of x-rays entering a multiple-bounce Bragg reflection channel-cut Ge(220) crystal (figure 1). In addition to the efficiency of the device, the full polarization state of the output beam including the purity of circular polarization P_c (figure 2) was measured directly using the multi-beam Bragg re-

flexion technique with a GaAs crystal polarimeter (see article p. 38). The reversibility of the circular helicity by changing the incident angle and the ability to scan the optics in energy was demonstrated at the vicinity of the Fe K-edge at 7.1 keV.

- [1] M. Blume and D. Gibbs, *Phys. Rev. B* 37, 1779 (1988); D. Mills, *ibid.* 36, 6178 (1987); D. P. Siddons, J. B. Hastings, G. Faigel, L. E. Berman, P. E. Hauslein, and J. R. Grover, *Phys. Rev. Lett.* 62, 1384 (1989); K. D. Finkelstein, Qun Shen, and S. D. Shastri, *Phys. Rev. Lett.* 69, 1612 (1992).
- [2] G. Schutz, W. Wagner, W. Wilhelm, P. Kienle, R. Zeller, R. Frahm, and G. Materlik, *Phys. Rev. Lett.* 58, 737 (1987).
- [3] H. Ktemura, *Synchrotron Rad. News*, Vol. 5 No. 1, 14 (1992).
- [4] M. Hart, *Philos. Mag.* B 38, 41 (1978); D. Mills, *Nucl. Instrum. Methods A* 266, 531 (1988); J. A. Golovchenko, B. M. Kincaid, R. A. Lovesque, A. E. Meixner, and D. R. Kaplan, *Phys. Rev. Lett.* 57, 202 (1986); K. Hirano, K. Izumi, T. Ishikawa, S. Annaka, and S. Kitata, *Jpn. J. Appl. Phys.* 30, 407 (1991).
- [5] S. D. Shastri, K. D. Finkelstein, Qun Shen, B. W. Batterman, and D. Welko, (to be published).
- [6] B. W. Batterman, *Phys. Rev. B* 45, 12677 (1992).

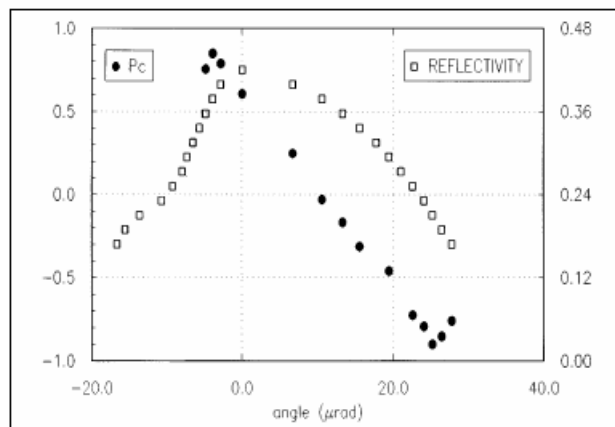

(Figure 2) The measured purity of circular polarization P_c as a function of incident angle at 7.07 keV. The reflectivity rocking curve of the 4-bounce Ge(220) channel-cut is also shown. Pure right or left circular radiation would be characterized by $P_c = 1$ or -1 respectively. $P_c = 0$ reflects equal amounts of right and left, as would occur when a beam is purely linear or completely unpolarized.